

EFEI 3115

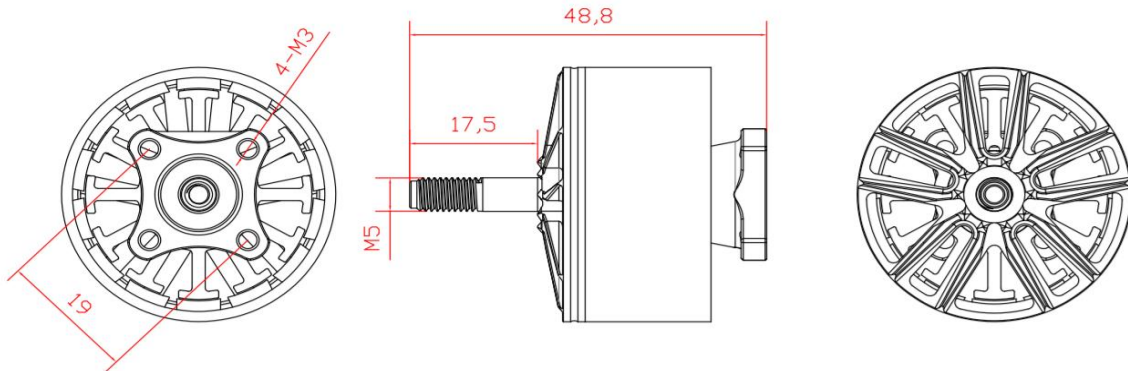

EFEI 3115

KV	900	Configuration	12N14P
Shaft	TC4	Stator	Kawasaki 0.2
Bearing	5*11*5	Magnet	N52SH(Curved Magnet)
Internal Resistance	44mΩ	Motor Cable	18#, 250mm
Shaft Diameter	5mm	Weight with silicone wire	109.6g

Extreme testing HQ1053-3 propeller 25V voltage for 29 seconds.

High temperature resistant 220° enameled wire

EFEI 3115

Item NO.	Propeller	Throttle	Thrust (g)	Voltage (v)	Current (A)	power (w)	Efficiency (g/w)	
EFEI-3115 KV900	HQ9*5*3-3	50%	2470	22.2	28.5	632.7	3.9039	
		60%	2680	22.2	33	732.6	3.6582	
		70%	2870	22.2	37.5	832.5	3.4474	
		80%	3065	22.2	42.3	939.06	3.2639	
		90%	3260	22.2	46.7	1036.74	3.1445	
		100%	3480	22.2	51.5	1143.3	3.0438	
EFEI-3115 KV900	HQ10*5*3-3	50%	2900	22.2	34	754.8	3.8421	
		60%	3130	22.2	39.5	876.9	3.5694	
		70%	3340	22.2	45	999	3.3433	
		80%	3570	22.2	50.8	1127.76	3.1656	
		90%	3785	22.2	56.3	1249.86	3.0283	
		100%	4015	22.2	62	1376.4	2.9170	
EFEI-3115 KV900	HQ10*5*3-3	50%	2260	25	21.8	545	4.1468	
		70%	3300	25	40	1000	3.3000	
		90%	4200	25	60	1500	2.8000	
		100%	4690	25	70	1750	2.6800	
EFEI-3115 KV900	HQ9*5*3-3	50%	2230	25.18	18.77	472.6286	4.7183	90° (Room temperature 31.2°)
		60%	2480	25.1	24.9	624.99	3.9681	
		70%	3000	25.05	33.6	841.68	3.5643	
		80%	3460	24.8	44.9	1113.52	3.1073	
		90%	3880	24.64	59	1453.76	2.6689	
		100%	4200	24.55	64.7	1588.385	2.6442	

EFEI-3115 KV900	GF 9045-3	50%	1900	25	16.98	424.5	4.4759	60.5° (Room temperature 33°)
		70%	2650	25	27.65	691.25	3.8336	
		90%	3800	25	52.5	1312.5	2.8952	
		100%	3920	25	56.5	1412.5	2.7752	

EFEI-3115 KV900	GF 1050-3	50%	2220	25	19.5	487.5	4.5538	79.4° (Room temperature 33°)
		70%	3070	25	35.9	897.5	3.4206	
		90%	4230	25	63.3	1582.5	2.6730	
		100%	4340	25	67.3	1682.5	2.5795	

Item NO.	Propeller	Throttle	Thrust (g)	Voltage (v)	Current (A)	power (w)	Efficiency (g/w)
32.5-12 KV535	GF-1308-3	50%	1468	25.11	9.73	244.3203	6.0085
		60%	1932	25	13.94	348.5	5.5438
		70%	2498	25	20.78	519.5	4.8085
		80%	2841	24.84	26.07	647.5788	4.3871
		90%	3233	24.77	35.64	882.8028	3.6622
		100%	3447	24.67	40.22	992.2274	3.4740

Item NO.	Propeller	Throttle	Thrust (g)	Voltage (v)	Current (A)	power (w)	Efficiency (g/w)
EFEI-3115 KV540	GF-1308-3	50%	1623	25.08	10.54	264.3432	6.1397
		60%	2213	25	16.48	412	5.3714
		70%	2606	24.92	22.56	562.1952	4.6354
		80%	2998	24.86	28.49	708.2614	4.2329
		90%	3387	24.79	38.15	945.7385	3.5813
		100%	3688	24.66	43.07	1062.1062	3.4723